

CAM strategies at machining

Líska Katalin

Department of Vehicle Technology, Kecskemét College, H UNGARY

Abstract: Paper focuses on the precision of components produced by CAM strategies. Today by the computer support are designed all resources and technologies for the component producing, their measuring, control and creates bigger requirements for the precision of products, quality and of course, price. This paper deals with the influence of CAM finishing strategies for the shape and dimension accuracy of surfaces.

Keywords: CAM strategies, finishing, CAD/CAM systems, milling, surface

1 Introduction

CNC controlled machine tools and CAM softwares raise the efficiency of the production of workpieces machined with cutting. Market competition among CAM software dealer companies can be experienced. With these softwares it is possible to machine complex, non-analytical surfaces in an accurate and rapid way. These workpieces can be used in several industries. We can often meet with freeform surfaces, for instance profile or molding tools. Using of CAD/CAM systems has several advantages. Built surfaces and toolpaths are handled flexibly, moreover it can be varied and monitored by softwares easily [1].

2 CAM STRATEGIES AT FINISHING

CAM softwares offers many finishing strategies for the producing of 3D surfaces, for the achieving of better surface roughness and shape accuracy. But, the toolpaths, designed by computer softwares, are not able to achieve perfectly during the production, by spherical, or cylindrical milling tool.

This follows from fact, that the tool path during machining consists from line segments. The machining precision affects several parameters.

The two most important parameters are the following:

- difference between the theoretical and the actual tool path (string mistake),
- imperfections due to the tool trace.

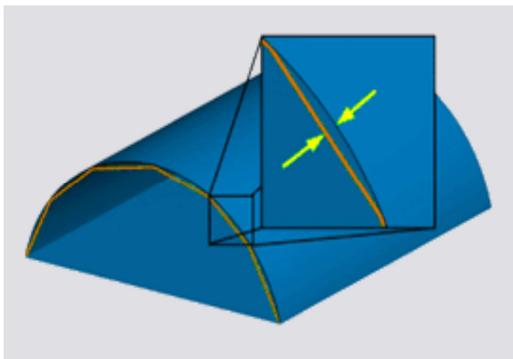

Figure 1. Difference between the theoretical and the actual tool path [1].

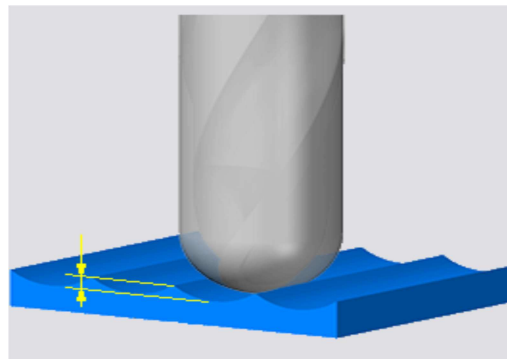

Figure 2. Imperfections due to the tool trace [1]

Now-known 3D and 5D finishing milling strategies are the following [5]:

- Milling by the projection. The movement of a milling machine is pre-defined in the XY plain and subsequently it is projected onto a model.

Pre-defined 2D paths in the XY plain can have these shapes:

- **spiral** (fig. 3)

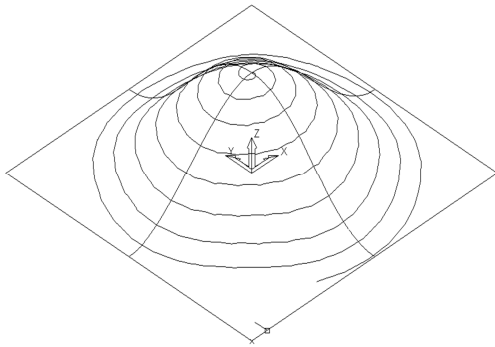

Figure 3. Movement after spiral [5]

- **radial shape** (fig. 4)

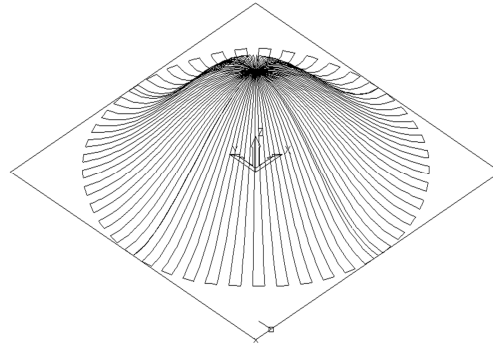

Figure 4. Movement after radial [5]

- **offset** (fig. 5),

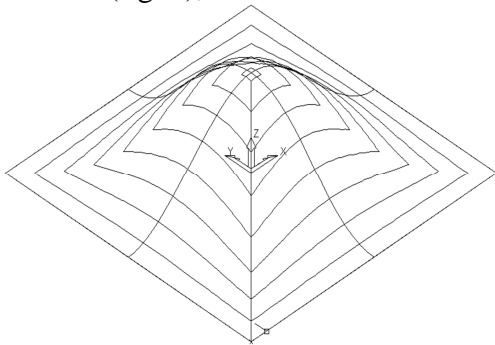

Figure 5. Movement after rectangles [5]

- **raster** (fig. 6).

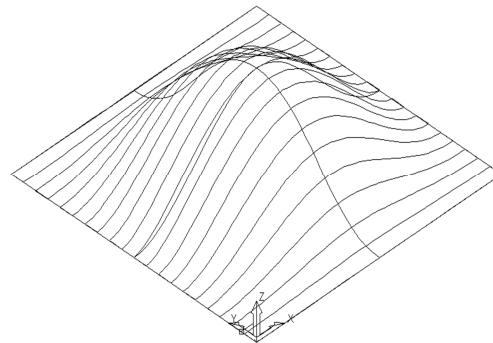

Figure 6. Strategy Raster decrescented to the centre [5]

3 METHODS AND MATERIALS USED FOR RESEARCH

In this topic you can find the machining conditions. In experiment was dealt with the machining of composite material with constant CAM strategy and various cutting conditions (fz).

Machining of composite materials is difficult to carry out due to the anisotropic and non-homogeneous structure of composites and to the high abrasiveness of their reinforcing constituents. This typically results in damage being introduced into the workpiece and in very rapid wear development in the cutting tool [2].

At experiment was used material GPO3 - fiberglass reinforced polymer laminate. This material is the industry standard for flame & arc/track resistant electrical components. GP03 also offers an excellent combination of high strength, flame resistance, and low smoke, flame, & toxicity generation [3].

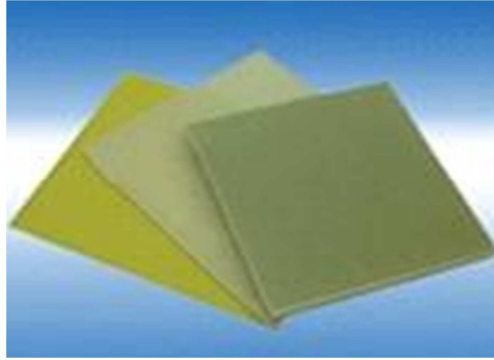

Figure 7. Composite GPO 3 [3]

The experiment was realized on the 5D CNC machining center NCT EmL-850D (Fig. 8), as workpiece was used material with mark GPO3 and as device was used chuck. The workpiece has size 80x80 mm. At roughing was used roughing cutter JC8609. The cutting parameters for roughing you can see in Table 1.



Figure 8. NCT EmL-850D machining centre

Table 1 Cutting parameters at roughing

V_c [m.min ⁻¹]	f_z [mm/tooth]	a_p [mm]	a_e [mm]	n [min ⁻¹]
50	0,016	4	8	1990

At finishing was used the ballnose end mill JC850, which you can see on Fig. 10. Cutting parameters for finishing are in Table 2.



Figure 10. Tool for finishing [4]

Table 2. Cutting parameters at finishing

V_c [m.min ⁻¹]	f_z [mm/tooth]	a_p [mm]	a_e [mm]	n [min ⁻¹]
50	0,1/0,3	0,3	0,3	1990

This research focused on investigation of the effect of constant CAM strategy on the roughness of cylindrical surface. This strategy was used at constant material and constant tool, at variable technological parameters.

As CAM software was used Mastercam X5. At selecting of strategy was considered the diversity of available strategies and the published developments.

On the base of these facts, the selected strategy was SPIRAL, one from the Mastercam X5 Surface High Speed Toolpaths. The „3D Toolpath Refinement was used, what is available at this strategy.

You can see the workpiece on Fig. 11.

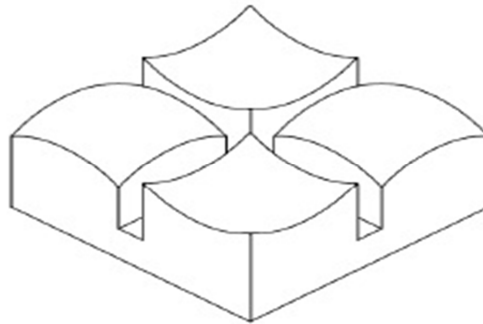

Figure 11. Workpiece

The following parameters were determined on the workpiece: R_a , R_z , R_q , R_t . On paper was focused on the R_a . The roughness was measured with Mitutoyo Formtracer SV-C3100 Contour and surface roughness measuring machine.

On Fig. 13 you can see the machined workpiece.

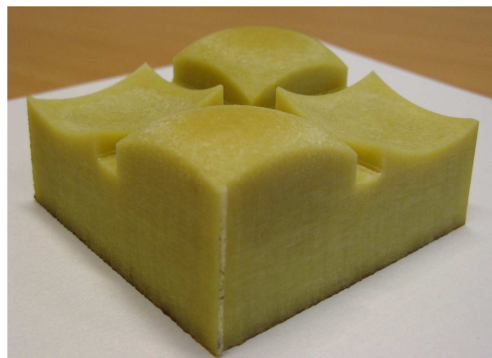

Fig. 13 machined workpiece

The roughness measurement of workpiece was follows: workpiece is from four separate parts, every part I deviced for three fields.

The deviced surface is on Fig. 14.

The surface roughness was measured on these three parts, on part A, B, and C.

The obtained values are shown in Table 3 and 4.

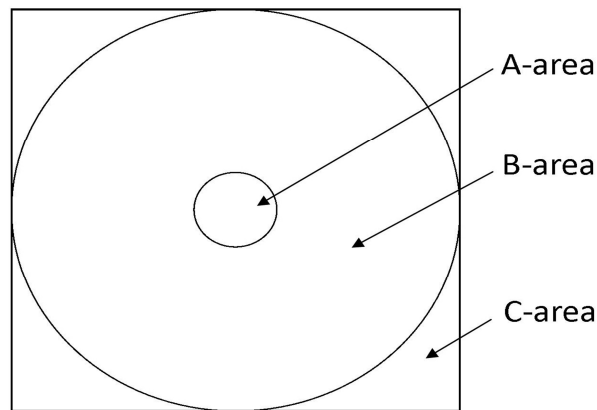

Fig. 14. the allocation of workpiece

Table 3. roughness at $f_z=0,3$ mm

concave			convex		
A	B	C	A	B	C
R_a [μm]					
3,20	4,41	6,05	3,21	3,36	5,39

Table 4. roughness at $f_z=0,1$ mm

concave			convex		
A	B	C	A	B	C
R_a [μm]					
3,40	3,50	4,21	3,01	3,50	3,66

On Fig. 15-17 you can find the evaluation of the measurements in zone A, B and C. The blue trend line indicates the convex surface, the red trend line indicates the concave surface.

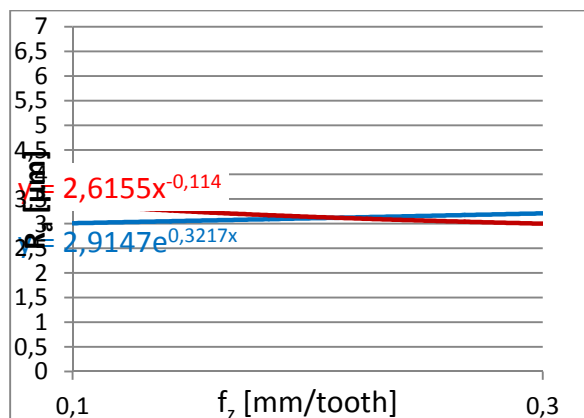

Figure 15. The feed-reducing effect of the convex and concave surfaces of the surface in A-zone

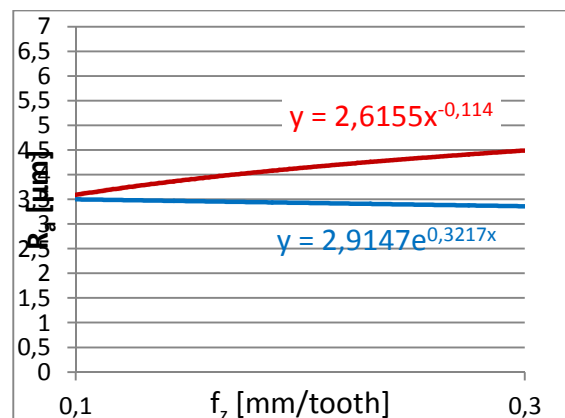

Figure 16. The feed-reducing effect of the convex and concave surfaces of the surface in B-zone

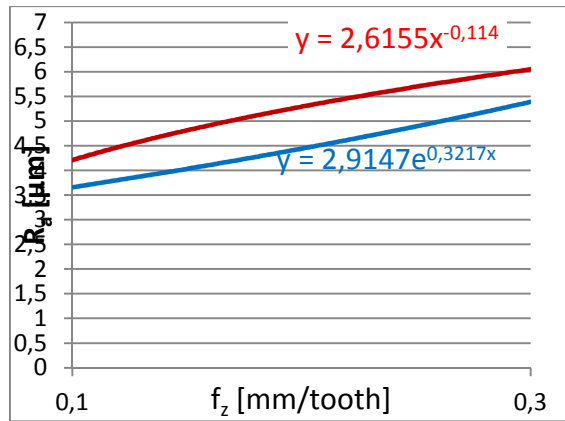

Figure 17. The feed-reducing effect of the convex and concave surfaces of the surface in C-zone

4 CONCLUSIONS

As the graph on Fig. 15. shows, in zone A, decreasing of f_z have a negative effect on the roughness of concave surface.

In zone B, decreasing of f_z have a positive effect on the roughness of concave surface.

This positive effect also applies at zone C, at concave and convex surface, too.

In zone B, decreasing of f_z at convex surface forms a negative effect.

The increasing roughness at zone A at concave surface and at zone B at convex surface, too can explained with fact, that the tool does not cut off the strings completely. It is also, because the v_c in these zones is near to zero.

Article was carried out within the framework of project with number TÁMOP 4.2.1./B-09/1/KONV-2010-0003.

5 REFERENCES

- [1] FÖLDVÁRI, N. Simító CAM stratégiák használata 3D és 5D felületek megmunkálásakor. Diploma thesis (2011).
- [2] Avaliabe on internet. <http://www.sciencedirect.com/science/article/pii/S000785060761703X>.
- [3] Avaliabe on internet. <http://www.youngmancn.com/gpo3.htm>
- [4] Seco tool catalog 2011,
- [5] KURIC, I., KOŠTURIK, J., JANÁČ, A., PETERKA, J., MARCINČIN, J. *Počítačom podporované systémy v strojárstve*. Žilina: Edis, 2001. 351 s., ISBN 80-7100-984-2.

Author data (Header style)

Katalin Liska: Department of Vehicle Technology, Faculty of Mechanical Engineering and Automation, Kecskemét College. Izsáki út 10., 6000 Kecskemét, Hungary. E-mail: liska.katalin@gamf.kefo.hu